

FEATURES:

- DIRECT DRIVE CONSTRUCTION (NO BELTS/PULLEYS).
- ROOF MOUNTED FANS.
- RESTAURANT MODEL.
- UL705
- VARIABLE SPEED CONTROL.
- INTERNAL WIRING.
- THERMAL OVERLOAD PROTECTION (SINGLE PHASE).
- HIGH HEAT OPERATION 300°F (149°C).

- NEMA 3R SAFETY DISCONNECT SWITCH.

NORMAL TEMPERATURE TEST
 EXHAUST FAN MUST OPERATE CONTINUOUSLY WHILE EXHAUSTING AIR AT 300°F (149°C) UNTIL ALL FAN PARTS HAVE REACHED THERMAL EQUILIBRIUM, AND WITHOUT ANY DETERIORATING EFFECTS TO THE FAN WHICH WOULD CAUSE UNSAFE OPERATION.

OPTIONS

2 YEAR PARTS WARRANTY.

CONTACT US 1-416-529-9274
 info@easykitchenhood.com

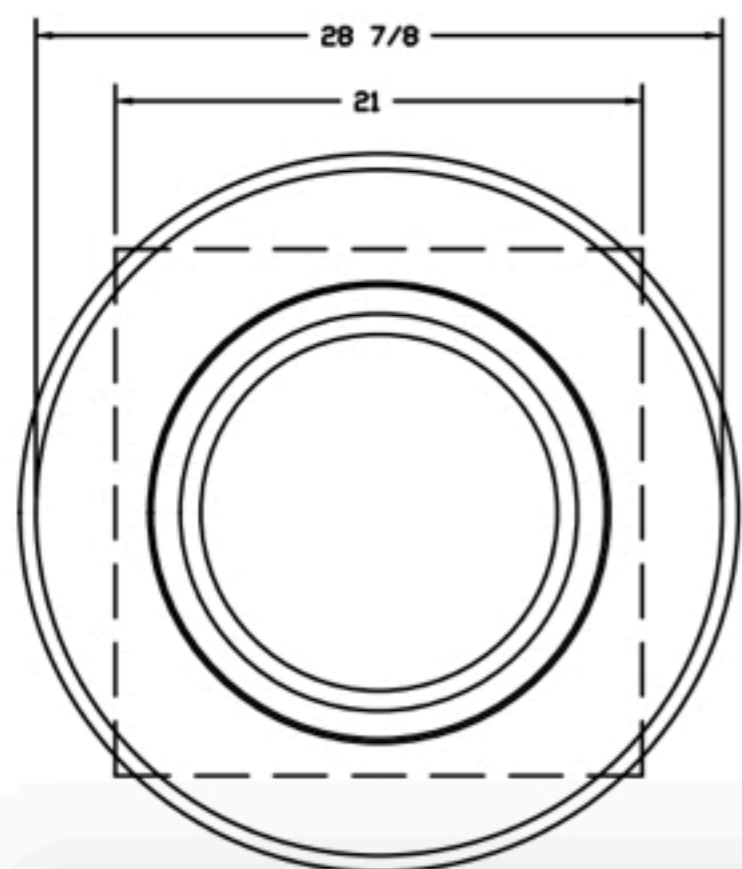

LOCATION , 0	
DATE 8/18/2021	JOB # 5038595
DWG # 1	DRAWN BY
REV.	SCALE 3/8" = 1'-0"